

# THE ES9311 DUAL LOW-NOISE, LOW-DROPOUT REGULATOR

## Simplifying Audio System Design

ESS Technology introduces the ES9311 dual +3.3V low-noise, low-dropout regulator, designed for high-performance audio DACs, including the ESS SABRE family. Featuring a revolutionary regulator architecture, the ES9311 contains both series-voltage and shunt-voltage elements and eliminates the need for output decoupling capacitors – an industry first in audio system design. The design provides very low-noise outputs that are necessary for driving the reference inputs of audio converters. The ES9311 is ideal for use with high-resolution audio (HRA) converters.

The ES9311 dual regulator replaces three active devices and several passive components used historically in audio system designs. Advantages for the system designer include: improved system performance, reduced bill-of-materials (BOM) and simplified design cycles for faster time-to-market.

A revolutionary step forward in audio building block technology, the ES9311 ensures seamless integration with ESS Technology’s mobile and professional SABRE DACs and headphone amplifiers. It is ideal for analog converters, smartphones, and HRA music players that require a very low noise level to deliver a premium audio experience for the most discerning professionals and audiophiles.



### ES9311 Block Diagram

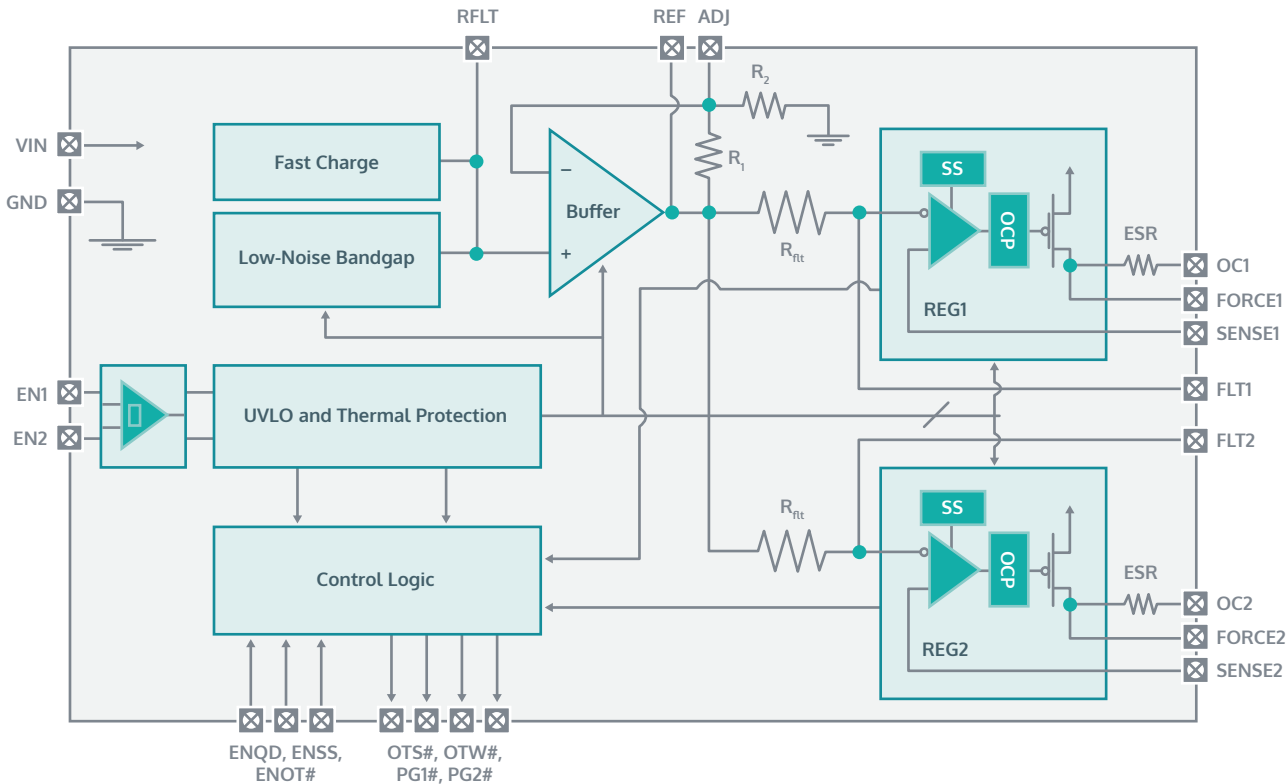

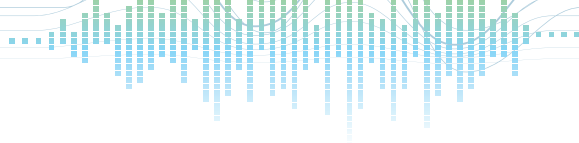

## Technical Specifications

This best-in-class dual, low-dropout regulator consists of a low-noise bandgap voltage reference, two high-performance low-noise low-dropout buffers, protection circuitry against over-current and over-temperature fault conditions, plus control logic and signaling. External filter capacitors are used to minimize output voltage noise to below  $1\mu\text{V}_{\text{rms}}$ . The regulated outputs use remote sensing to maintain voltage accuracy at the load under varying load currents, and the output voltage can be trimmed, if required, to be exactly +3.3V.

## Additional Features and Benefits

Feature	Benefit
Output voltage noise is $<1\mu\text{V}_{\text{rms}}$ from 100 Hz to 100 kHz to maintain high DNR when used as the voltage reference on audio converters	Maintains high DNR when used as the voltage reference on audio converters
Four active-low status outputs; Power Good signals for each output, over-temperature warning at 105°C, and over-temperature shutdown at 130°C	Over-temperature warning at 105°C, and over-temperature shutdown at 130°C
Under-Voltage Lockout (UVLO) function to stop voltages appearing on the +3.3V outputs when the supply voltage is less than +3V	Prevents unwanted noise from being injected into audio DACs or ADCs at startup
Three enable inputs: one each for the two outputs, and one to enable or disable the over-temperature shutdown (OTS) function Disabling the OTS is required in some high-availability communications systems.	Disabling the OTS is required in some high-availability communications systems

## Audio Operating Circuit

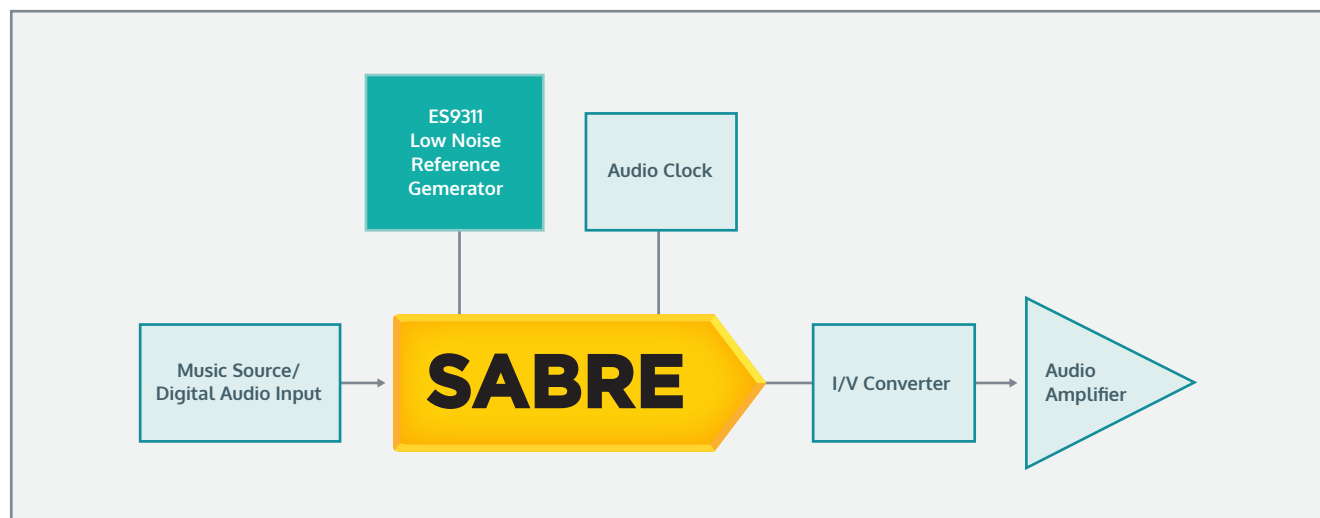

## About ESS Technology

For more than three decades ESS Technology has been on the cutting edge of audio technology. A privately held fabless semiconductor company, ESS Technology designs and markets high-performance analog and HiFi audio devices for mobile, consumer, automotive, and professional audiophile systems. The company was founded in 1984 and today ESS Technology is best known for its SABRE series of high-performance audio products. For more information visit <http://www.esstech.com>.